

LIVE

FR 80

Speaker

- Extended frequency response
Full-range driver 3" (80mm)
- Max. power: 100 W / Nom. power: 25 W
- Frequency response 200 Hz - 35 KHz
- Impedance 3 Ohms

ABS PC Basket - Ultra rigid carbon fiber cone - IIR surround - Long life "conex" spider - 20mm Voice Coil, fiber glass former - Oversized neodymium ring Magnetic motor - T Yoke equipped with a copper ring which limits the creation of Foucault currents - Aluminum magnesium dust cap - Products matched to + -1 dB

Guy Bonneville

BLAM

DRIVEN BY PASSION



TECHNICAL SPECIFICATIONS

Component	Woofer	
Max power	100 W	
Nominal power	25 W	
Impedance	3 Ω	
Freq. Response	200 Hz -35 KHz	
Sensitivity (2,83V/1m)	92 dB	
Magnet	Neodymium	
Magnet size Ø x h	50 x 9 mm	1,969" x 0,354 "
Total driver displacement	0,0527 l	0,002 cf
Weight of one component	0,255 kg	0,562 lb
Voice coil Ø	20 mm	0,787"
Voice coil height	6 mm	0,236"
Cone	Carbone fiber	

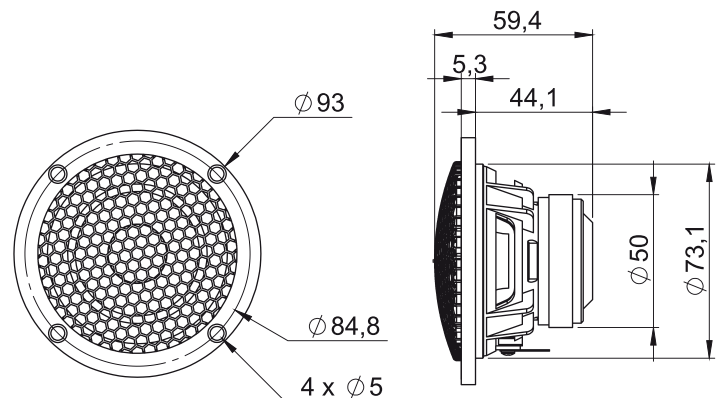

FREQUENCY RESPONSE / IMPEDANCE

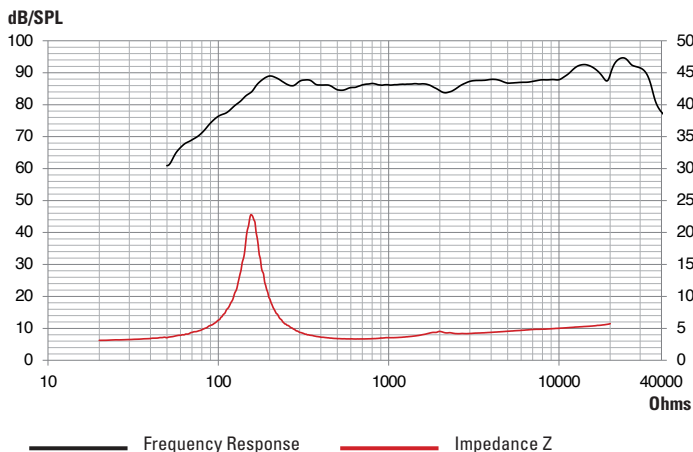

THIELE-SMALL PARAMETERS

effective Ø (d)	61 mm
Sd	29,22 cm ²
Xmax	1,00 mm
Re	3 Ω
Fs	157,27 Hz
Le	18,06 kHz
L2	127,56 µH @10 kHz
Vas	0,67 L
Mms	1,82 g
Cms	0,000562 m/N
BL	2,86 Tm
Qts	0,57
Qes	0,66
Qms	4,35
Sensitivity (dB/W/m)	87,8 dB

contact@blam-audio.fr
www.facebook.com/blamaudio
www.blam-audio.fr